

WT-35VS Serialization System

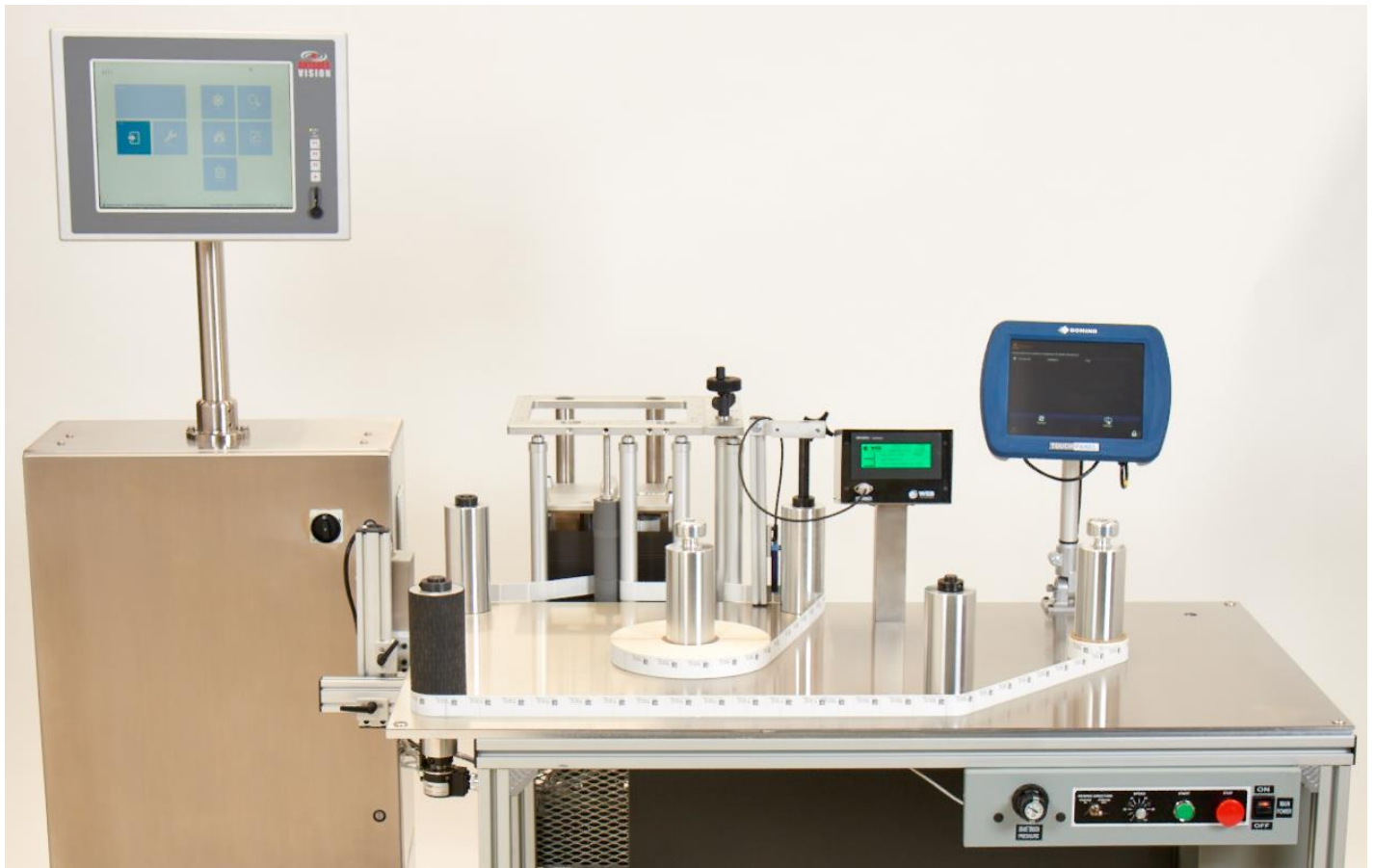

910 BOLGER COURT. FENTON, MO 63026 . USA
(800) 325-9777 (636) 343-0806 FAX: (636) 343-6629
sales@webtechniquesinc.com | webtechniquesinc.com



WT-35VS REWIND SYSTEM WITH PRINTING AND VISION INTEGRATION FOR A COMPLETE SERIALIZATION SOLUTION IN A SMALL PACKAGE

SAVE MONEY AND TIME BY QUICKLY AND ACCURATELY COUNTING, SERIALIZING, VALIDATING AND REWINDING YOUR LABELS WITH AN INTEGRATED SERIALIZATION REWIND SYSTEM.

BECOME GOVERNMENT COMPLIANT AND IMPROVE CONSUMER SAFETY ALL WHILE GAINING A BETTER UNDERSTANDING AND CONTROL OF YOUR INVENTORY.

ADDITIONALLY, SERIALIZATION MINIMIZES CHARGEBACKS ASSOCIATED WITH PACKAGING ERRORS AND CONSUMER CLAIMS AS WELL AS IMPROVING PRICING ACCURACY.

SOLVE YOUR LABEL INVENTORY ISSUES WITH A WEB TECHNIQUES REWIND SYSTEM

ALL OF THESE BENEFITS ARE AVAILABLE IN A FLEXIBLE, AFFORDABLE SOLUTION.

FEATURES:

1. MULTIPLE PRINTING OPTIONS

No matter if your application needs thermal transfer, ink jet or any other continuous motion printing solution the WT-35VS Serialization System can provide the solution you need

2. PEDESTAL MOUNTED HIGH VISIBILITY, BACKLIT TOUCH SCREEN CONTROL

Dual Preset: Set one point for deceleration and a second point for final stop. Counts in both English or Metric Units at the touch of a button

3. (OPTIONAL) MULTI-LANE COUNTING OPTION

4. (OPTIONAL) DATA LOGGING SYSTEM

5. (OPTIONAL) WEB CLEANING SYSTEM

6. ALUMINUM EXTRUDED CONSTRUCTION

Easily add options in the field utilizing the extruded aluminum frame

7. CONSTANT SPEED CONTROL

Allows system to automatically maintain desired web speed

8. MISSING LABEL DETECTION

9. UNREMOVED MATRIX DETECTION

10. CONSTANT SPEED CONTROL

Creates a "standstill" effect, allowing visual inspection at high speeds. Energy Efficient!

11. (OPTIONAL) BARCODE VALIDATION

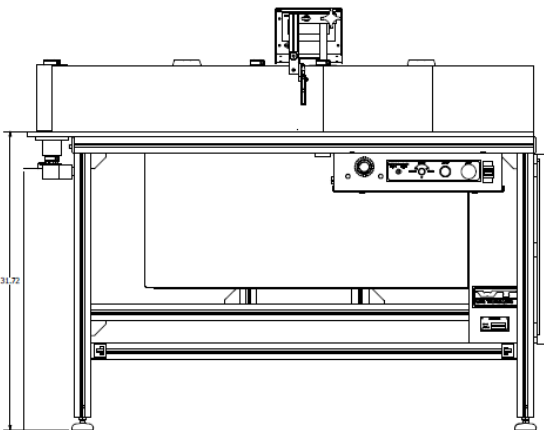

12. CHOICE OF COREHOLDER SIZES

Coreholders range in size from coreless to 0.4" through 6" (25mm through 120mm), Please do not hesitate to contact us with any special requests. Low Tension Coreholder now available!

13. CHOICE OF COUNTING SYSTEMS

Our systems are compatible with almost any counting system available, Please do not hesitate to contact us with any special requests

14. (OPTIONAL) SPLICE DETECTION SYSTEM

15. (OPTIONAL) COMPRESSED AIR MODULE

Allows WT-35 system to be operated in locations with no compressed air availability

16. (OPTIONAL) QUADRATURE COUNTING OPTION

*100% Guaranteed Count

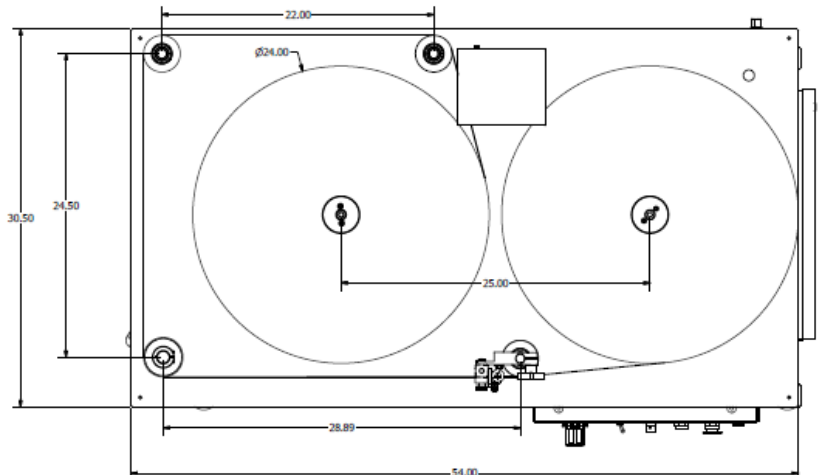

910 BOLGER COURT. FENTON, MO 63026 . USA
(800) 325-9777 (636) 343-0806 FAX: (636) 343-6629